

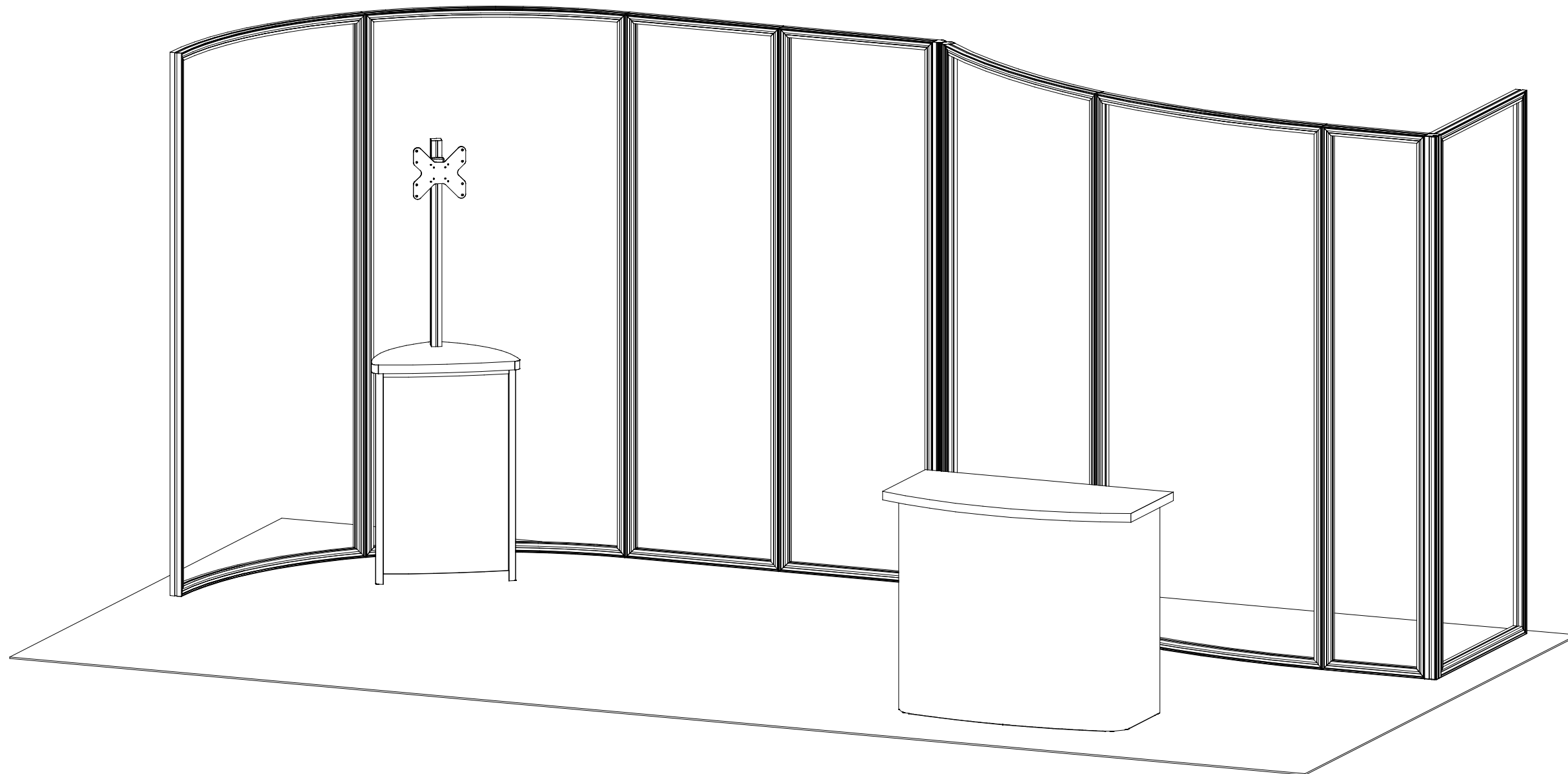

20'

10'  
Top View

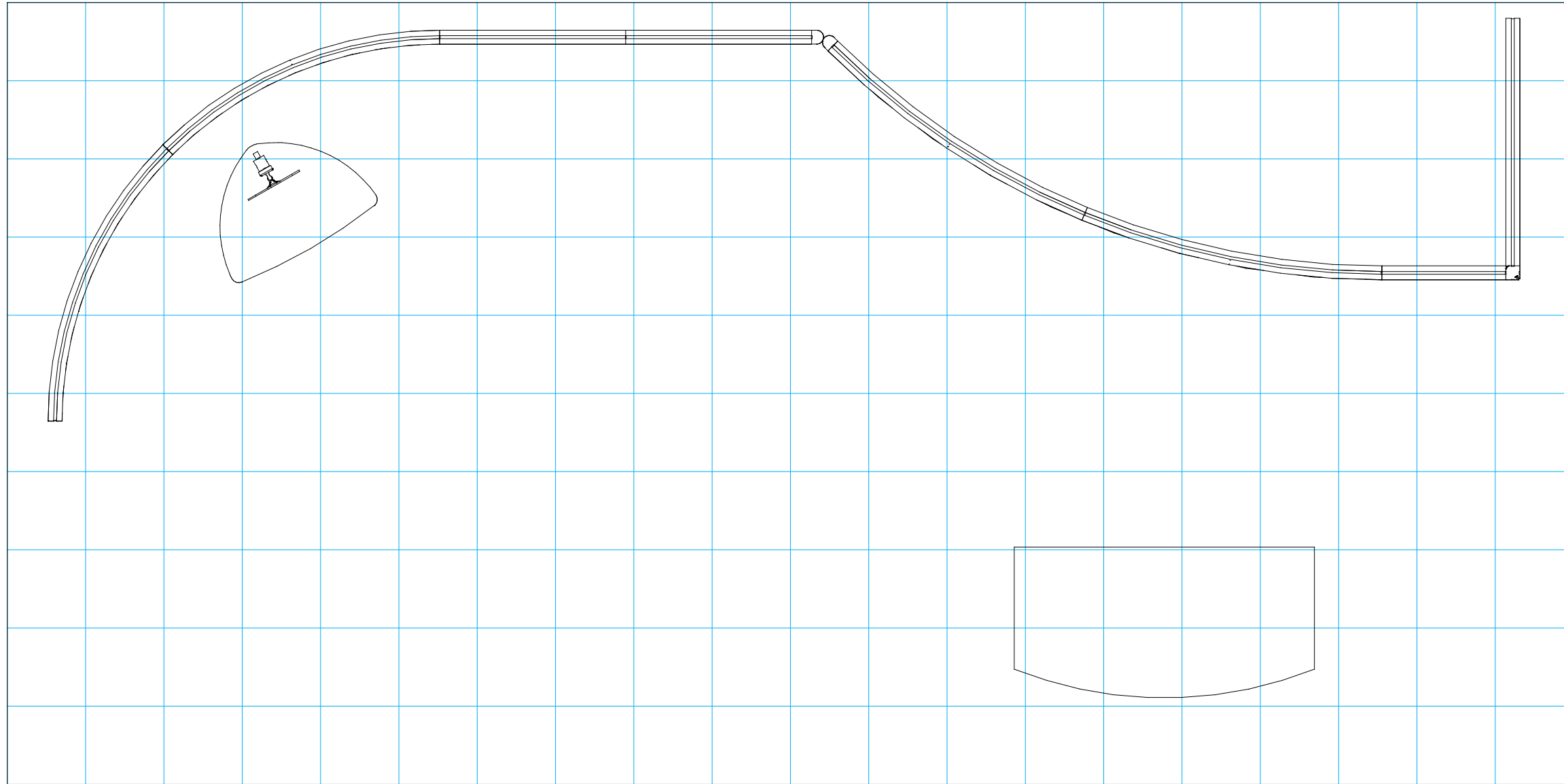

# SETUP INSTRUCTIONS



 = 1 sq foot

## General Setup Instructions

- Read entire setup instruction manual prior to unpacking parts and pieces.
- The setup instructions are created specifically for this configuration.
- Setup instructions are laid out sequentially in steps, including exploded views with detailed explanation for assembly.

## Cleaning & Packing

- For Cleaning Metal, Plex, & Laminate Parts: Use a **MILD NON-ABRASIVE** cleanser and soft cloth/paper towel to clean all surfaces.
- Keep exhibit components away from heat and prolonged sun exposure. **Heat and UV exposure will warp and fade components.**
- Retain all provided Packing Materials. All provided packing materials are for ease of repacking & component protection.

## Disassembly

- For loss prevention, tighten all set screws and locks during disassembly.

### Assembly

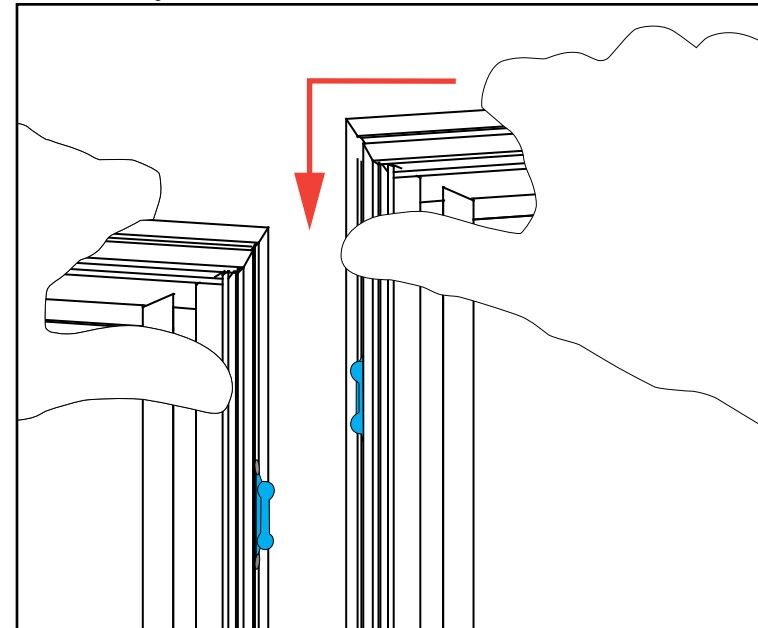

### Side-by-Side Assembly

- 1) Frames: Place frames side-by-side with one higher than the other, then slide panel down to lock panels securely together.
- 2) Corner Connectors: Repeat Step 1 for installing corner connectors to frames.

### Assembly Cont'd

Push pin lock into hole of connecting frame.  
Note: Block on pin lock will secure in groove.

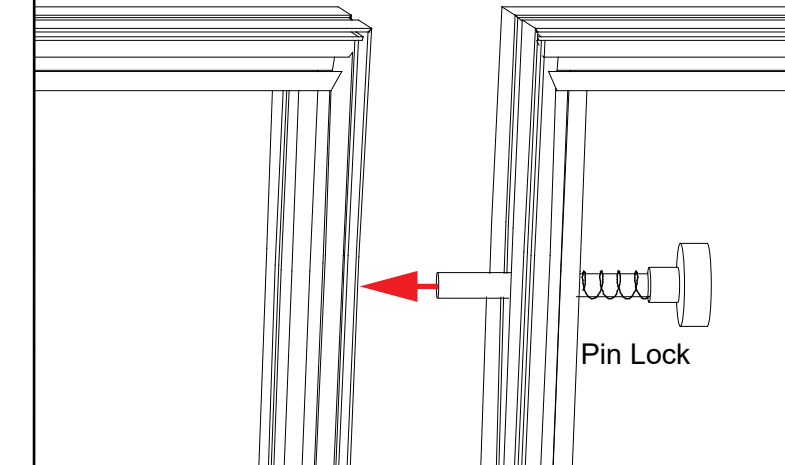

### Side-by-Side Disassembly

- 1) Pull pin lock outwards to disengage.
- 2) Pull frames upward and apart at the same time to detach.

## SEG Graphic Installation in 3 Steps

The Perfect Fit

### STEP 1: Attach Corners

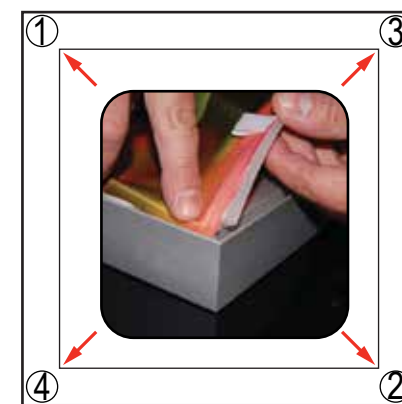

Always insert graphic into each alternate corner, then into the sides of the frame. Otherwise the graphic will not fit into the frame correctly.

Insert narrow side of silicone welt into the channel at corner 1, with fabric to the outside. Repeat for opposite corner 2, then corner 3, then corner 4.

### STEP 2: Attach Middle

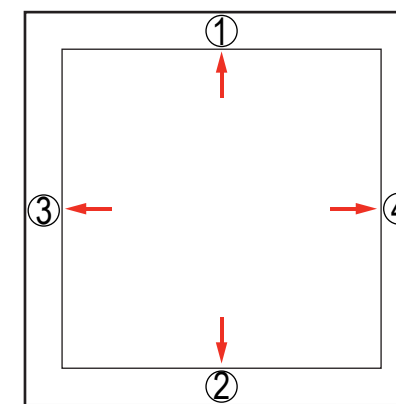

Once corners are attached, press the middle of edge 1 into the channel. Then press middle of edge 2 into the channel on opposite side. Repeat with edge 3 & 4.

### STEP 3: Attach Sides

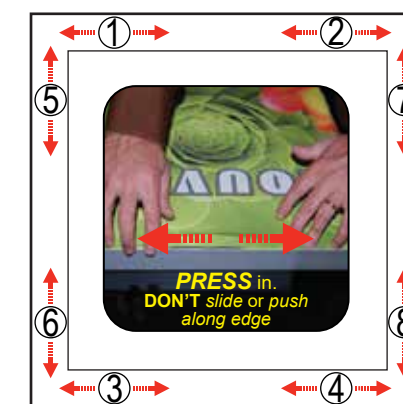

Once the middle of sides are attached, fully press the silicone welt into the channel, between center and corner at location 1. Repeat the process between center and corner at location 2.

Do the same for welt on opposite side, at locations 3 & 4. Then repeat for locations 5 & 6 and 7 & 8.



To remove graphic from the frame, locate the fabric pull tab. Gently pull on the tab to remove the graphic.

Install video:



CRATE PACKING

Item	Qty.	Description
1	1	38"w x 95"h Gravitee Panel
2	1	94.5"h Gravitee corner post w/ caps
3	1	19"w x 95"h Gravitee Panel
4	1	46"w x 95"h curved Gravitee Panel
5	1	46"w x 95"h curved Gravitee Panel
6	1	95"h Gravitee hinged connector
7	1	28.5"w x 95"h Gravitee Panel
8	1	28.5"w x 95"h Gravitee Panel
9	1	46"w x 95"h curved Gravitee Panel
10	1	46"w x 95"h curved Gravitee Panel

Steps:

Refer to the Gravitee Assembly general information page.

- 1) Assemble Gravitee panels & posts [1] through [10] in numerical order as shown.

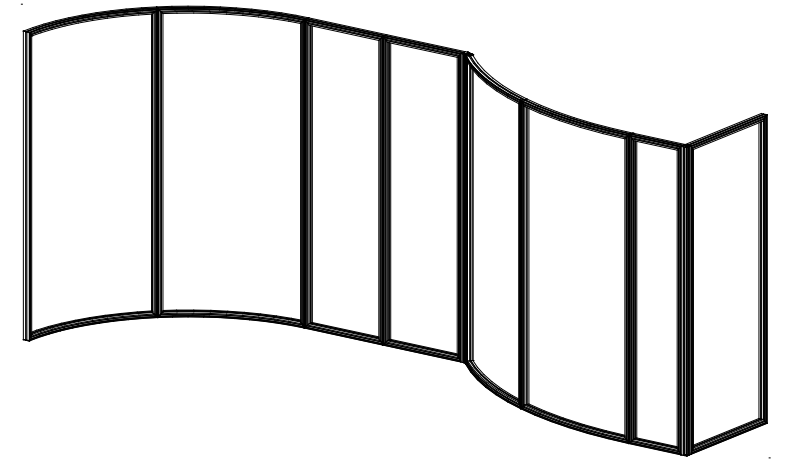

When assembled

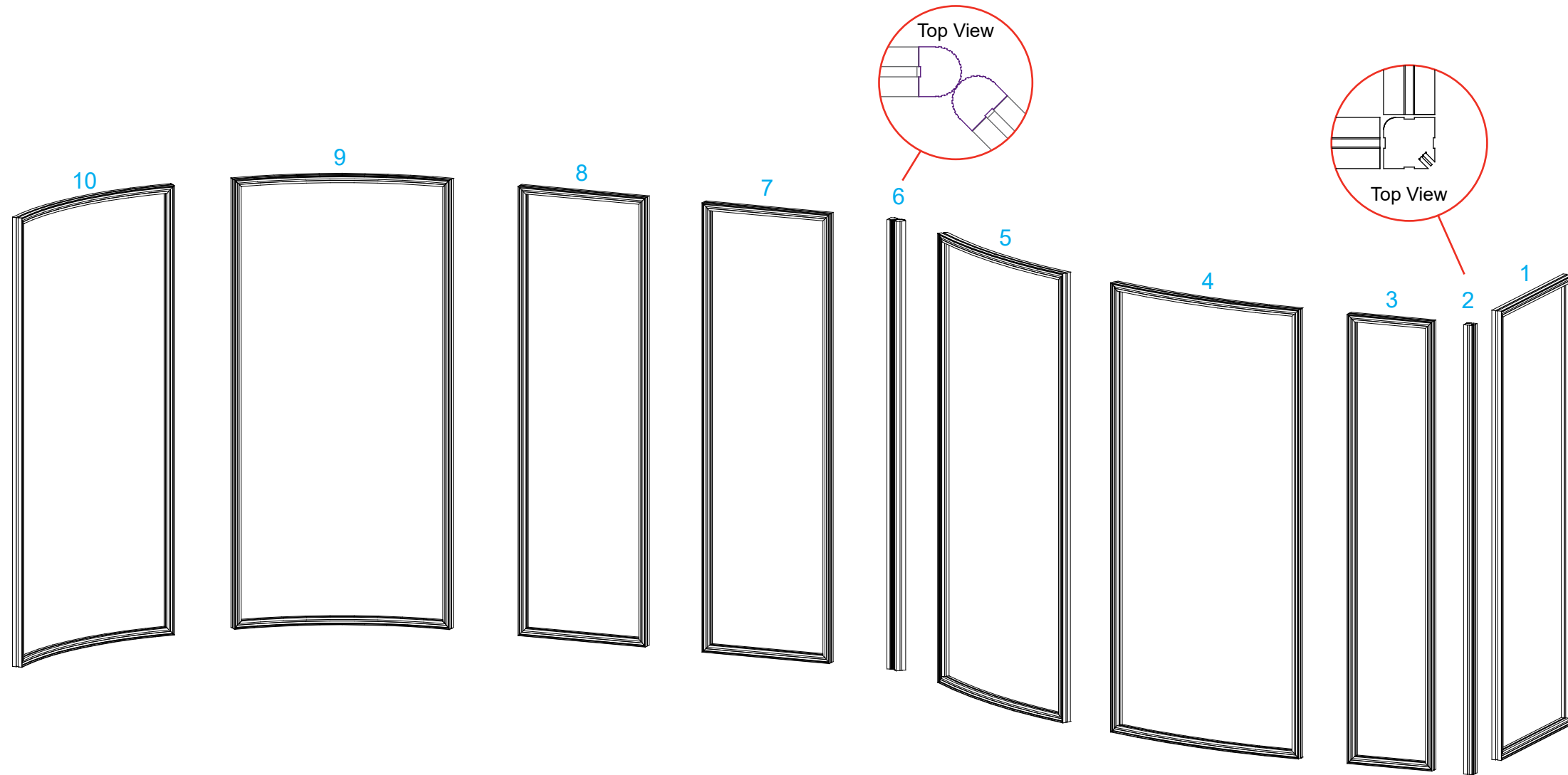

FRONT VIEW

## SEG Graphic Installation

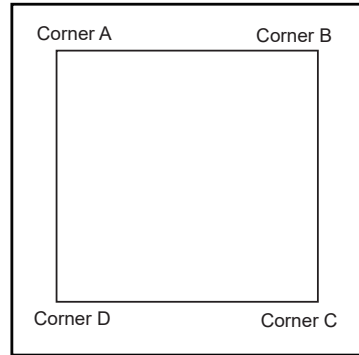

It is important to first insert graphic into each alternate corner, then to the sides of the frame. If this is not done, graphic will not fit into the frame correctly.

**Step 1**  
Insert corner A. Turn edge of graphic so silicon welt is perpendicular to face of graphic. Insert narrow side of welt with fabric to outside into the channel. Repeat for other side of this corner.



**Step 2**  
Repeat Step 1 for opposite corner C, then insert corner B, followed by corner D, to complete the installation of the corners.



**Step 3**  
Once all corners are inserted, press one silicon edge into channel from corners and work toward the center. Make sure welt is fully inserted into channel. Continue until all sides are done. Smooth out edges of graphic.



### Graphic Removal

To remove the graphic from the frame, locate the fabric pull tab. Gently pull up on the tab to remove the fabric.

Steps:

- 1) Apply SEG graphics to backwall panels as shown.
- 2) Connect lights to top of panels where indicated. See **Light Attachment** detail.

### \* Light Attachment

Lock Clip into Groove of Horizontal Extrusion, then slide Light onto Clip.



Slide light into light receiving hardware

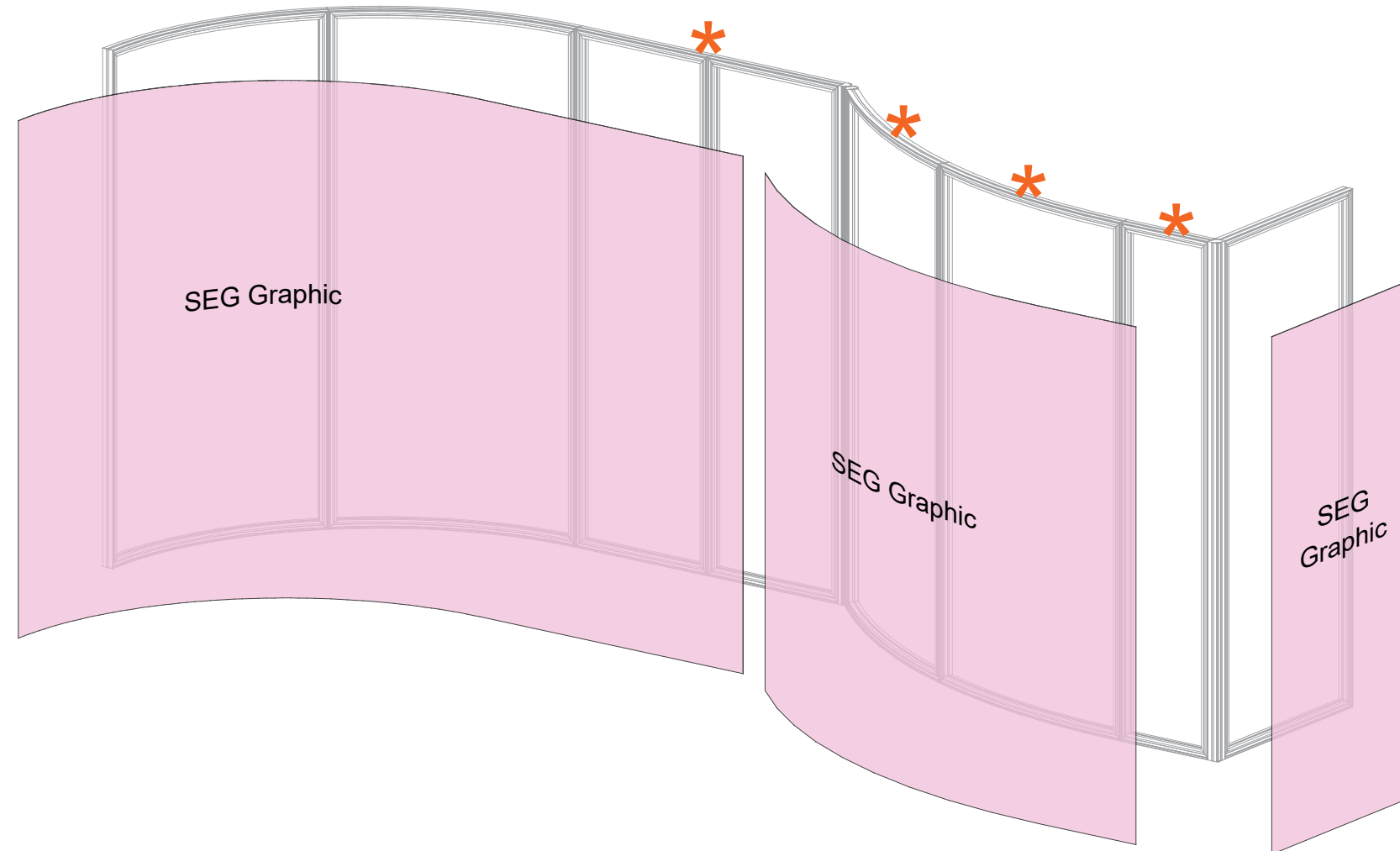
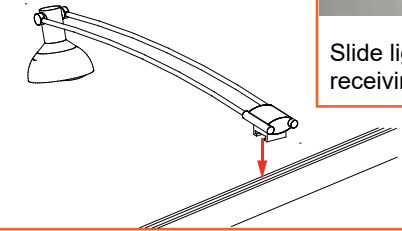

FRONT VIEW

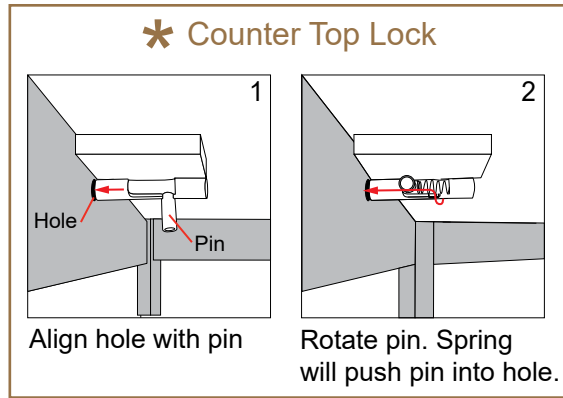

Item	Qty.	Description
1	1	38" GS210 Vertical Extrusion
2	1	38" S30 Vertical Extrusion
3	1	38" S30 Vertical Extrusion
4	2	18.8496" Z45 Curved Extrusion
5	1	21.7196" Z45 Curved Extrusion
6	2	18.8496" Z45 Curved Extrusion
7	1	21.7196" Z45 Curved Extrusion
8	1	36" S44 Vertical Extrusion

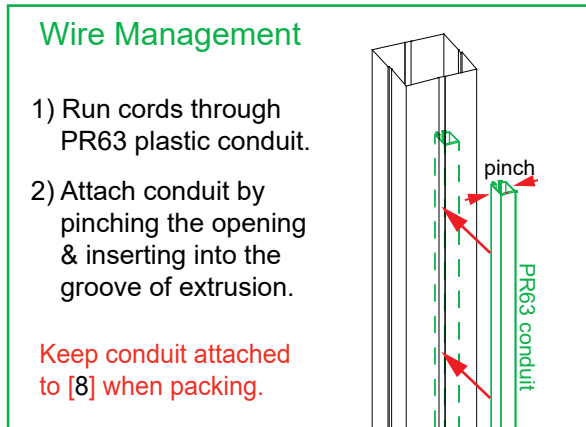

- Steps:
- 1) Attach horizontals [4,4,5] between verticals [1,2,3]
  - 2) Slide floor between verticals [1,2,3] to rest on [4] and [5].
  - 3) Insert pins into [1,2,3] where shown.
  - 4) Slide shelf between [1,2,3] to rest on pins.
  - 5) Slide infill between [2] and [3].
  - 6) Attach horizontals [6,6,7] between [1,2,3] to secure infill.
  - 7) Lock counter top to [6]. See **Counter Top Lock** detail.
  - 8) Attach vertical [8] to counter top, using bolt.
  - 9) Attach monitor mount to [8]. See **Monitor Mount** detail.
  - 10) Attach monitor to mount, then route monitor cord through conduit. See **Wire Management** detail.

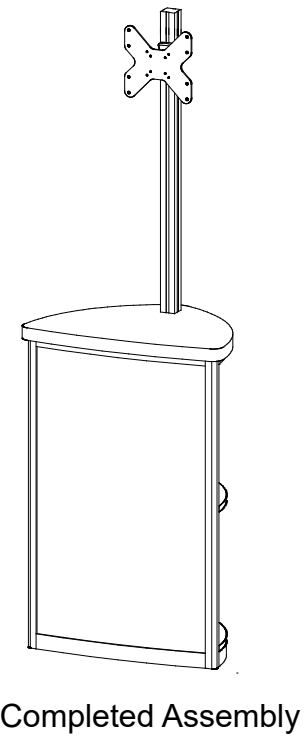
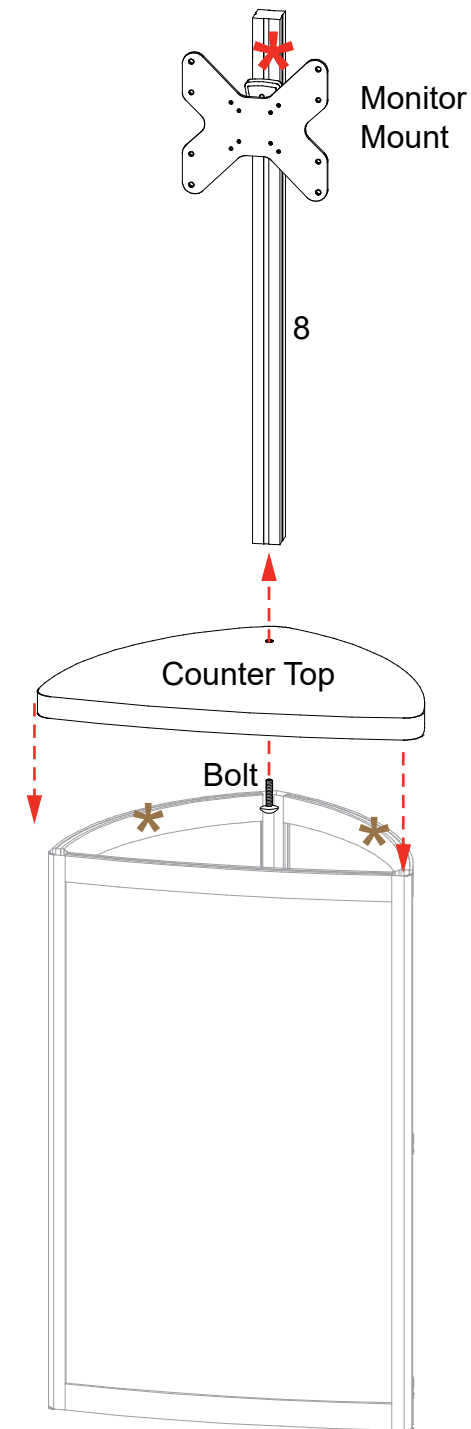
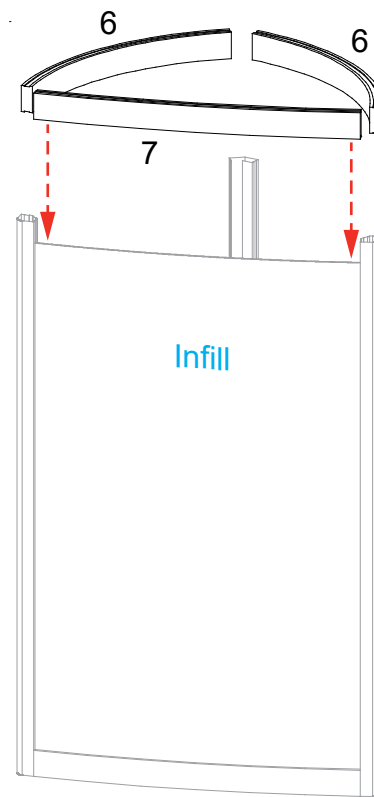
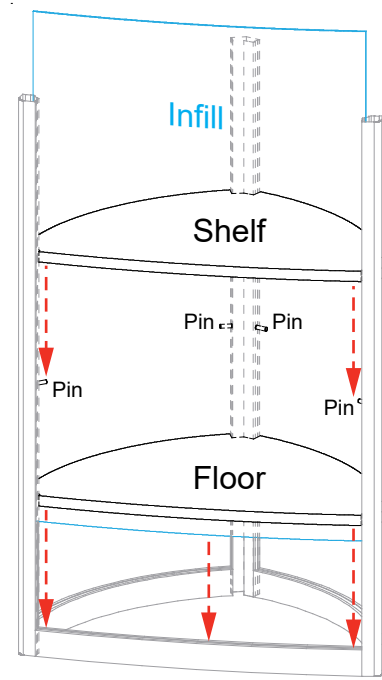
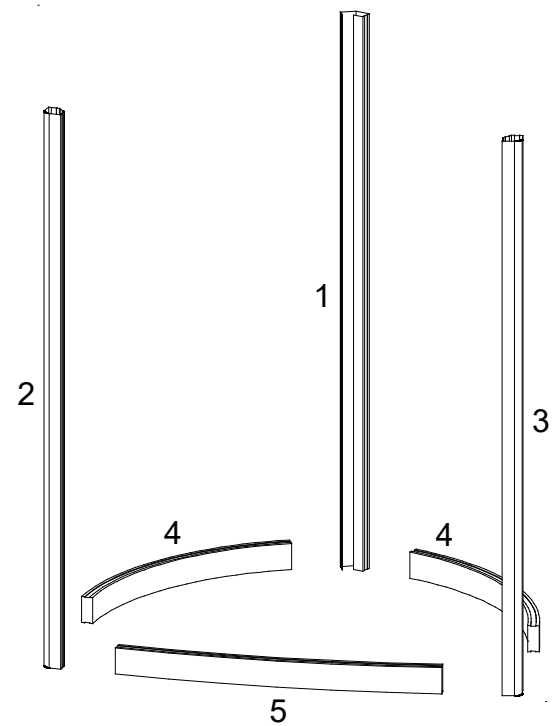

**\* Monitor Mount Attachment**

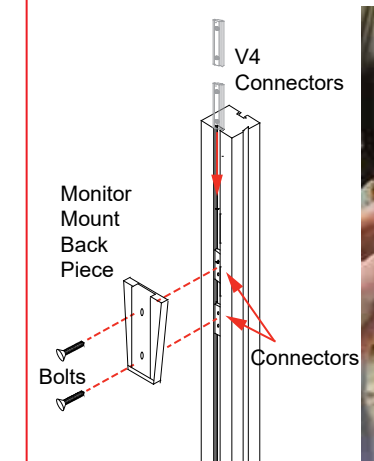

Slide V4 Connectors into groove of Extrusion. Tighten Set Screws to secure connectors in place.

Attach Monitor Mount back piece to Extrusion, using bolts.

Then slide monitor mount into back piece.



Item	Qty.	Description
11	1	37.5"h Gravitee Corner Post w/ caps & door hinge
12	1	11.5"w x 38"h Gravitee Panel
13	1	37.5"h Gravitee Hinged Connector
14	1	18.327"w x 38"h curved Gravitee Panel
15	1	18.327"w x 38"h curved Gravitee Panel
16	1	37.5"h Gravitee Hinged Connector
17	1	11.5"w x 38"h Gravitee Panel
18	1	37.5"h Gravitee Corner Post w/ caps w/ caps & door hinge
9	1	37.094"w Z45 Horizontal Extrusion
10	1	37.094"w Z45 Horizontal Extrusion
11	1	34.417"h Z45 Horizontal Extrusion w/ Door Stops

Steps:

Refer to the Gravitee Assembly general information page.

- 1) Assemble Gravitee panels & posts [11] through [18], in numerical order as shown.
- 2) Attach horizontal extrusions [9,10] between posts [11,18].
- 3) Connect vertical [11] between horizontals [9,10].
- 4) Install Doors to [11] & [18]. See [Door Attachment](#) detail.

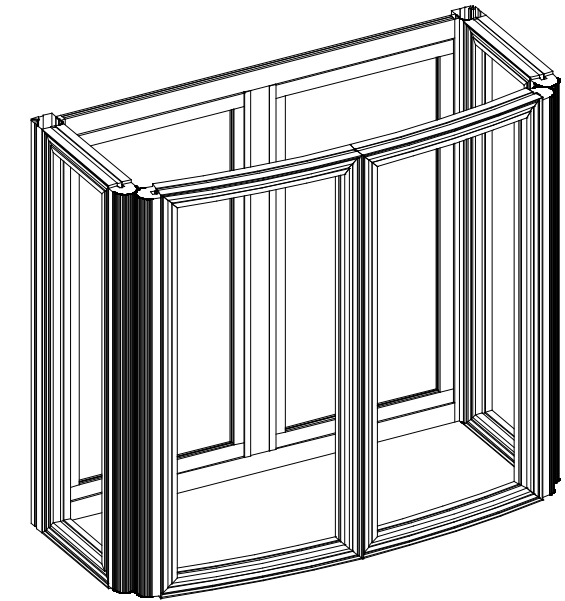

When assembled

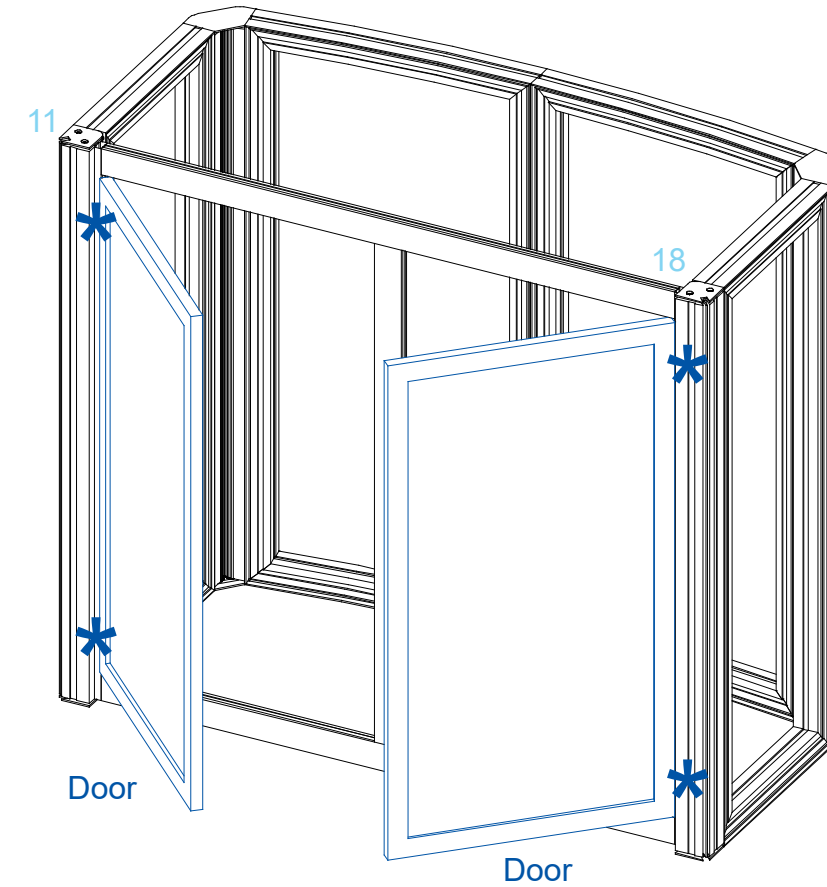
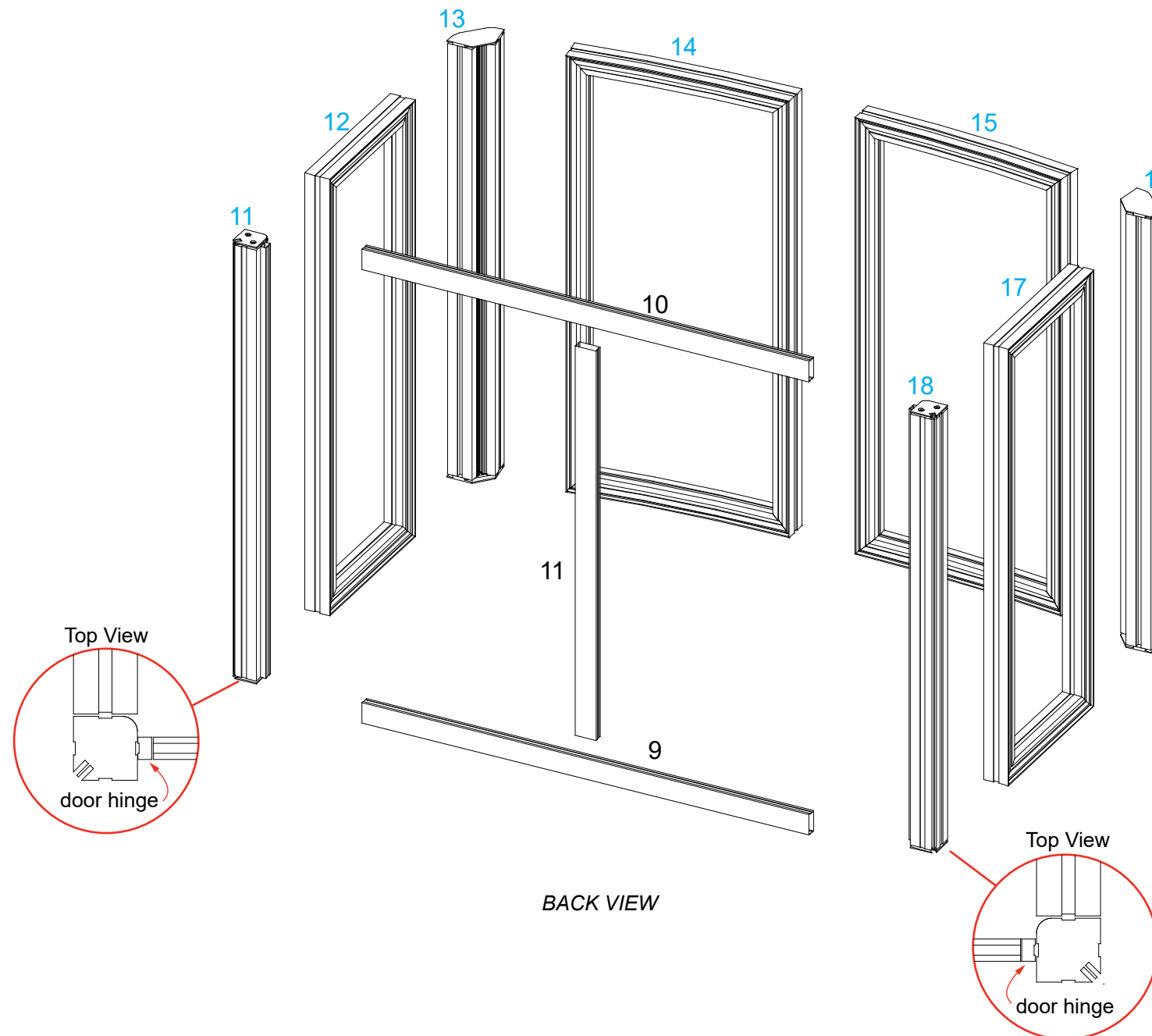

**\* Door Attachment**

Slide pin into hinge attached to vertical.  
Slide door hinge over pin.

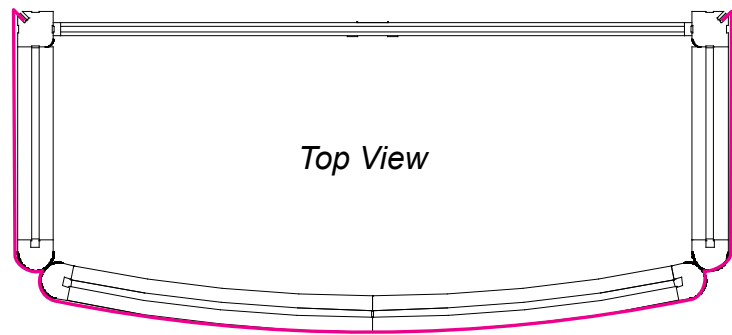

Steps:

- 1) Wrap SEG Graphic around front & sides of Counter, as shown.
- 2) Attach Shelf Supports using Velcro; place Internal Shelf.
- 3) Place Counter Top on top of assembly & secure in place.

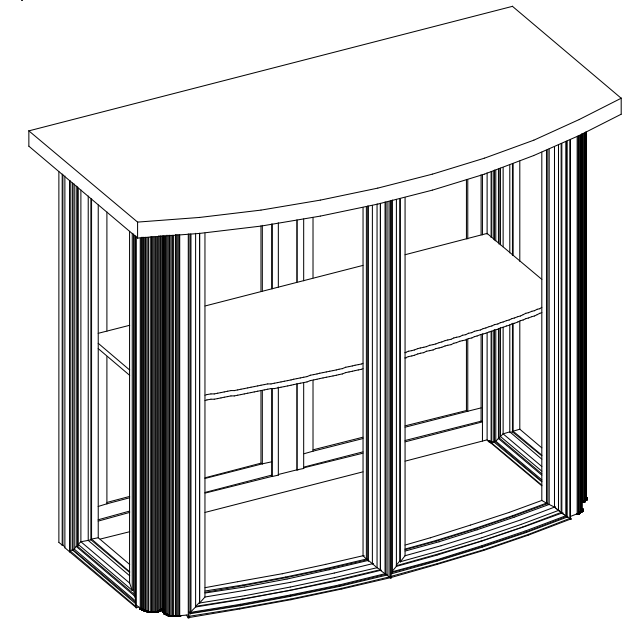

When assembled

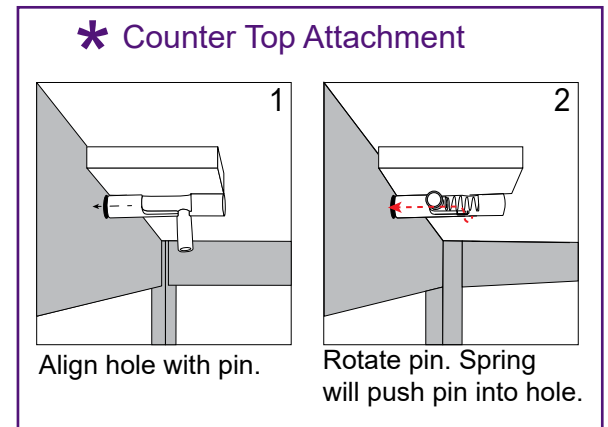
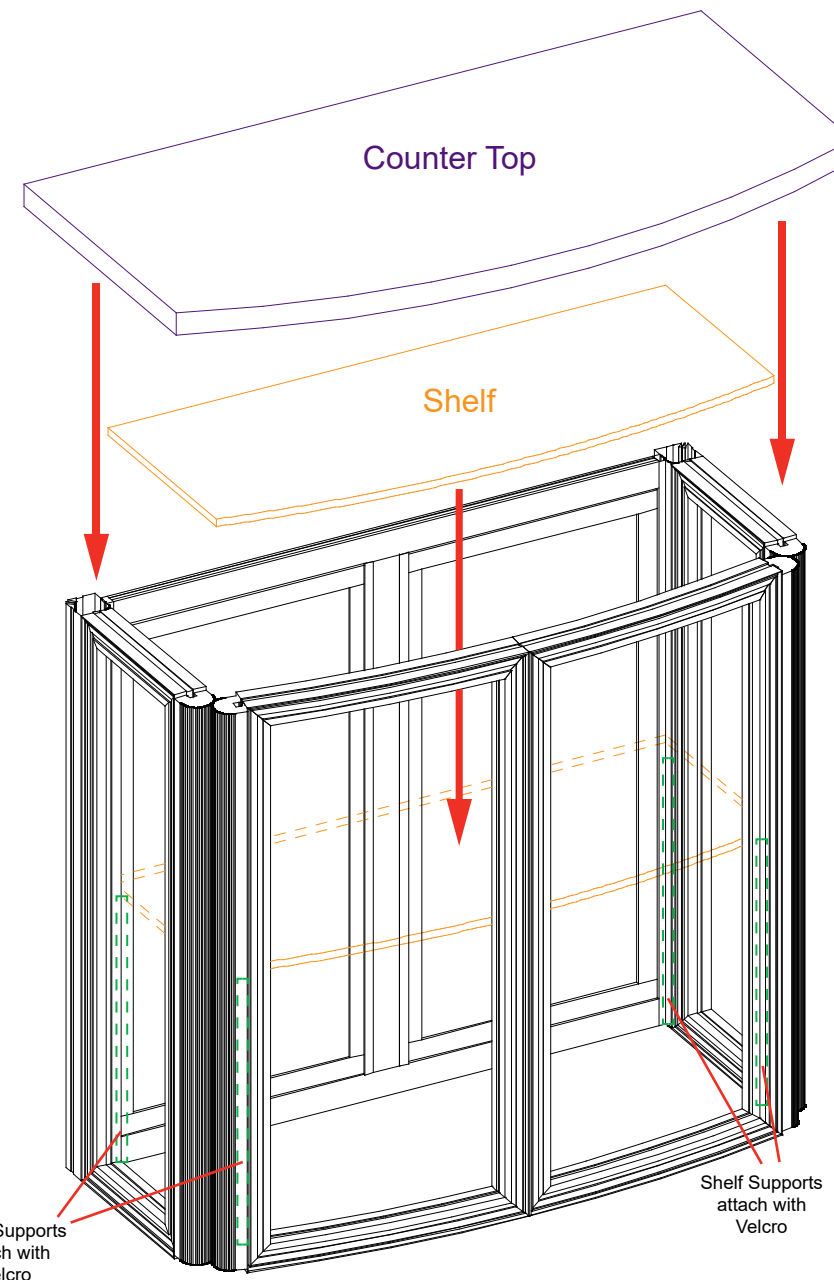
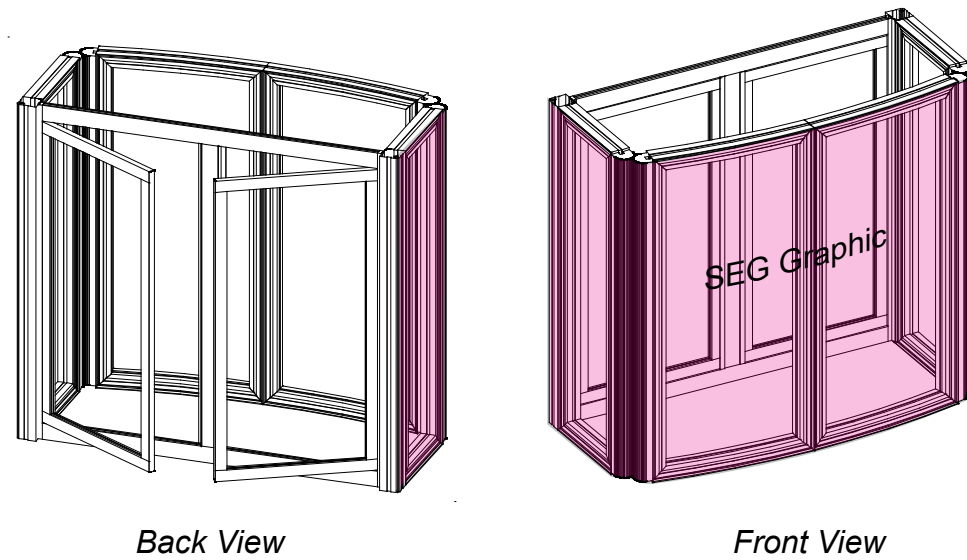

## SEG Graphic Installation

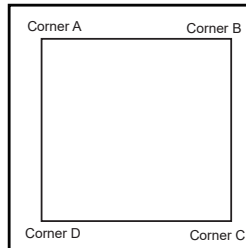

It is important to first insert graphic into each alternate corner then to the sides of the frame. If this is not done, graphic will not fit into the frame correctly.



Step 1  
Insert corner A. Turn edge of graphic so silicon welt is perpendicular to face of graphic. Insert narrow side of welt with fabric to outside into the channel. Repeat for other side of this corner.



Step 2  
Repeat Step 1 for opposite corner C, then insert corner B, followed by corner D, to complete the installation of the corners.



Step 3  
Once all corners are inserted, press one silicon edge into channel from corners and work toward the center. Make sure welt is fully inserted into channel. Continue until all sides are done. Smooth out edges of graphic.

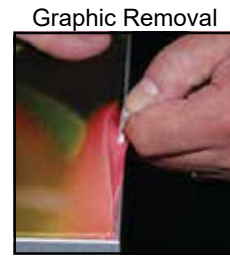

Graphic Removal  
To remove the graphic from the frame, locate the fabric pull tab. Gently pull up on the tab to remove the fabric.